

Fifth Avenue



FIFTH AVENUE uses traditional screen printing techniques, meaning beautiful overlays vary on each tile to produce an authentic, hand made look.

PRODUCT TYPE: Screen print porcelain

COLOURS: Pyramid Pale, Pyramid Mono, Pyramid Blue, Stripe Pale, Stripe Mono, Chevron Multi, Chevron Green

SIZES: 150x150mm
Rectified edges

FINISHES/USAGE: Matt/Wall and floor (soft shoe only)

AESTHETIC QUALITIES: Screen print, Geometric patterns

VARIATION:

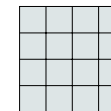

V1

NB: Custom made patterns and colours can be produced with a minimum quantity of 35 square metres.

Fifth Avenue

PYRAMID

PRODUCT SPECIFICATIONS

SIZES	FINISHES	TILE EDGE
150x150mm	MATT	RECTIFIED

FORMATS

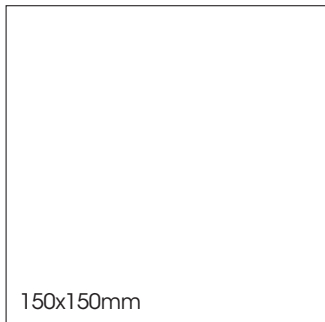

PYRAMID PALE

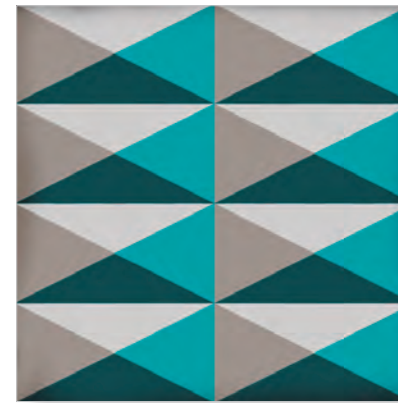

PYRAMID BLUE



PYRAMID MONO

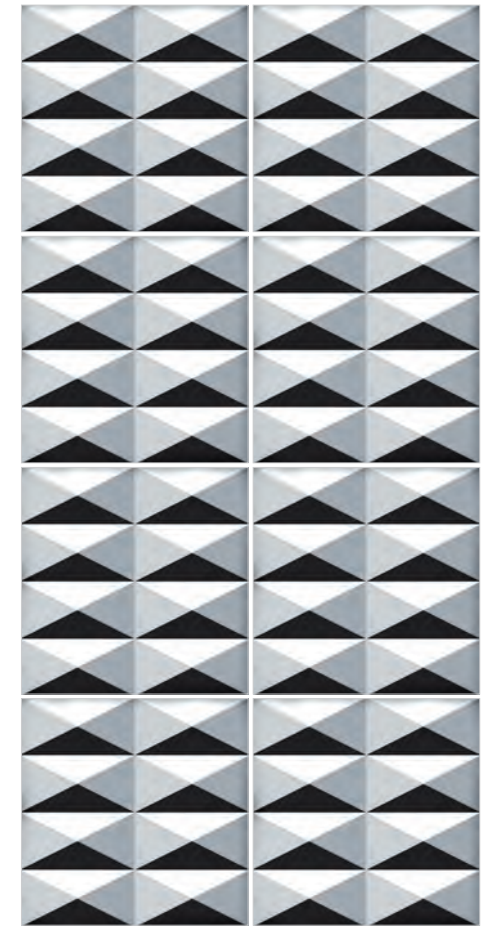

Fifth Avenue

CHEVRON

PRODUCT SPECIFICATIONS

SIZES	FINISHES	TILE EDGE
150x150mm	MATT	RECTIFIED

FORMATS

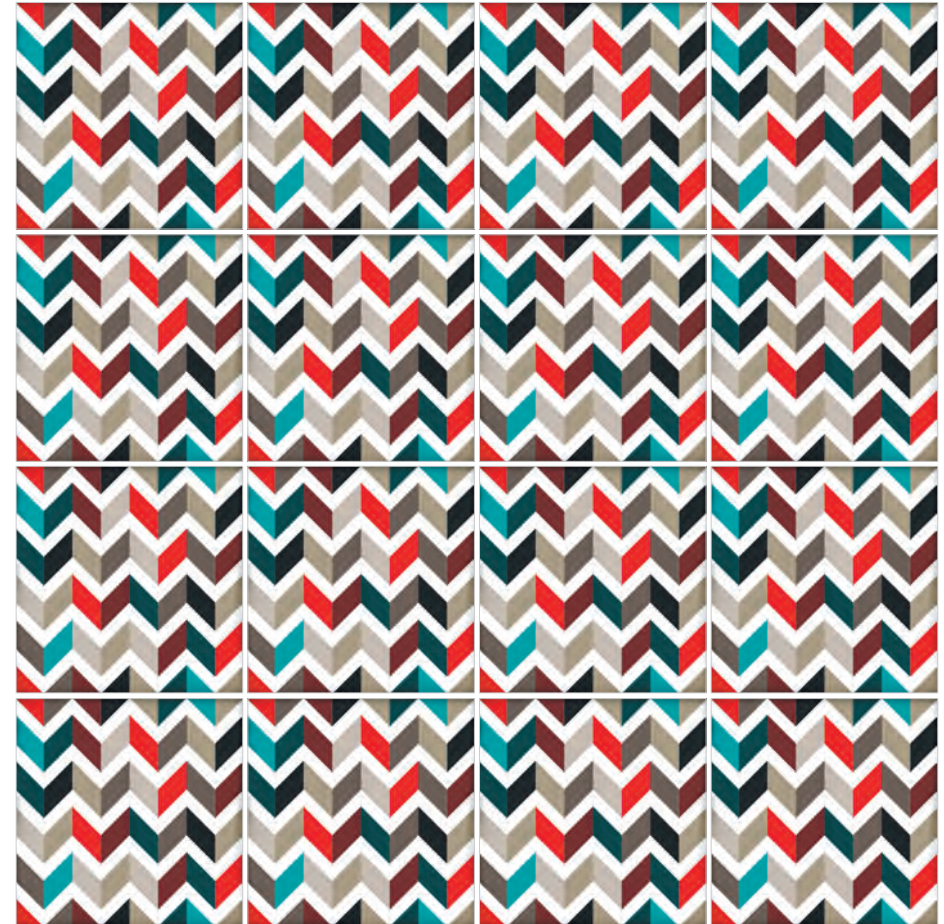
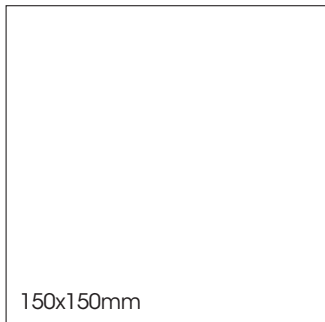

Fifth Avenue

CHEVRON

PRODUCT SPECIFICATIONS

SIZES	FINISHES	TILE EDGE
150x150mm	MATT	RECTIFIED

FORMATS

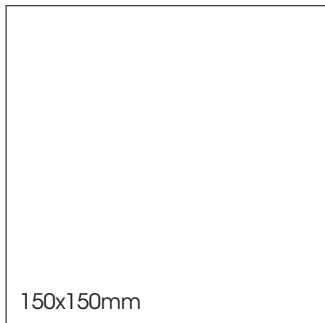

CHEVRON GREEN



Fifth Avenue

STRIPE

PRODUCT SPECIFICATIONS

SIZES	FINISHES	TILE EDGE
150x150mm	MATT	RECTIFIED

FORMATS

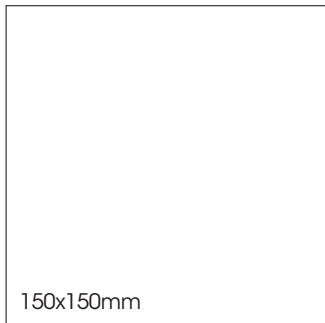

STRIPE PALE



STRIPE MONO

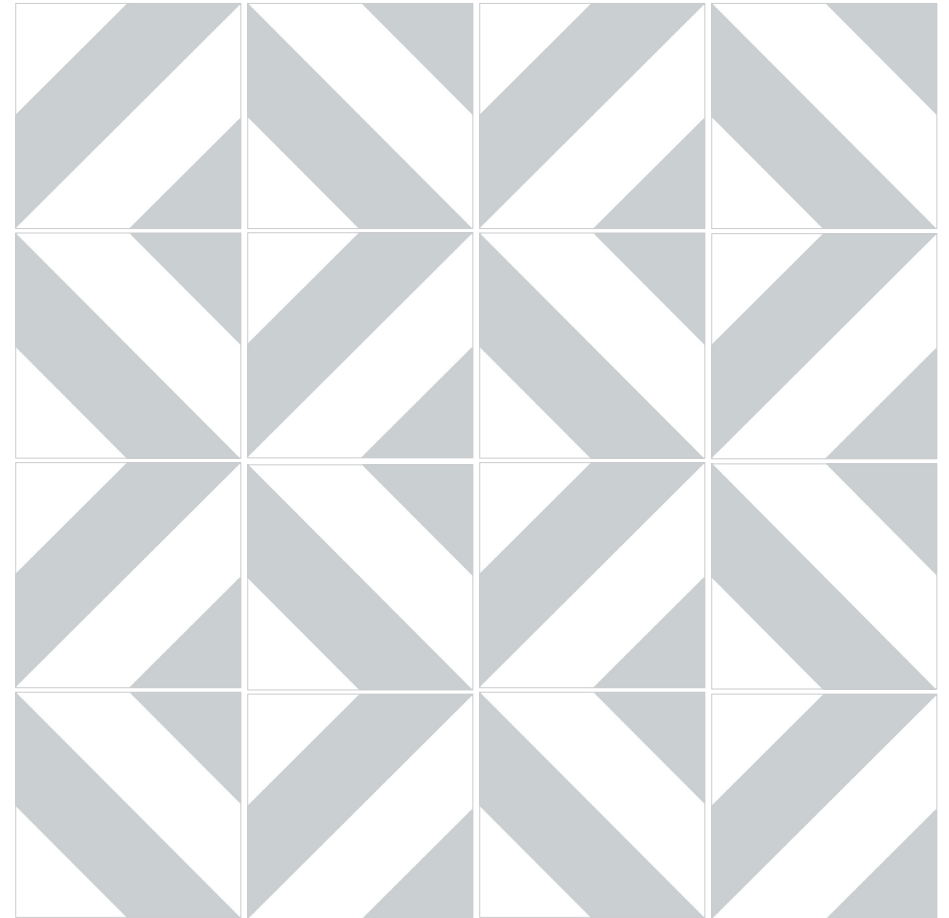

LAYING PATTERNS AND SUGGESTIONS

Fifth Avenue

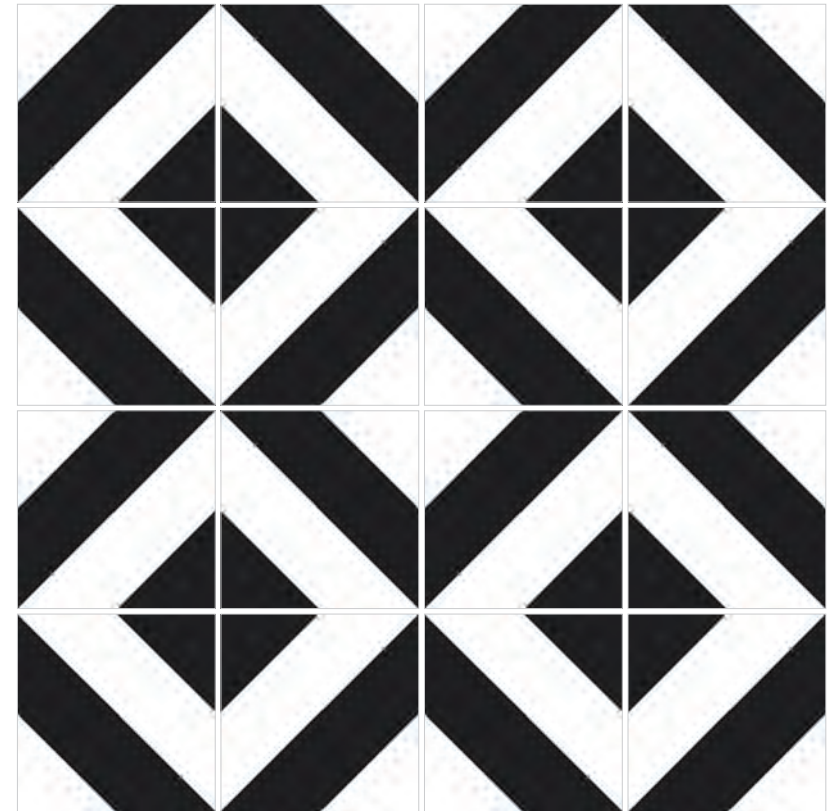
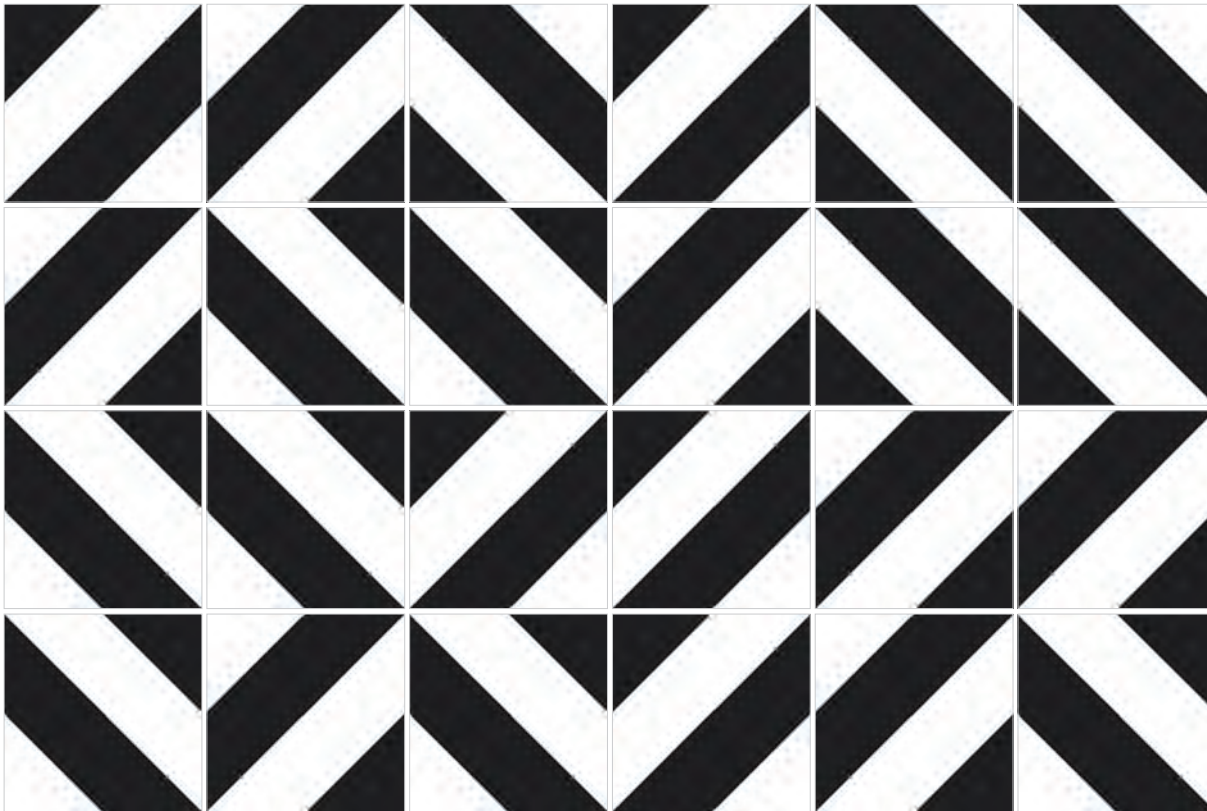

Fifth Avenue



Fifth Avenue

