

Avenue



PRODUCT TYPE: Glazed Porcelain

COLOURS: White, Mist, Fawn and Stone

SIZES: 300x300mm, 300x600mm and 600x600mm
Rectified Edges

FINISHES/USAGE: Matt, and Grip/Wall and Floor

AESTHETIC QUALITIES: Limestone look

TECHNICAL INFO: Matt - P2 Pendulum Slip rating
Grip - P5 Pendulum Slip rating
More information on last page

VARIATION:

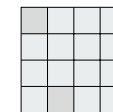

V2

AVENUE is a hybrid of stone and limestone look tiles. With subtle movement and colour variation which can be applied for internal wall and floors.

Avenue

PRODUCT SPECIFICATIONS

SIZES	FINISHES	TILE EDGE	SLIP RATING
300x300mm	MATT	RECTIFIED	P2 Pendulum
300x600mm	MATT	RECTIFIED	P2 Pendulum
600x600mm	MATT	RECTIFIED	P2 Pendulum
300x600mm	GRIP	RECTIFIED	P5 Pendulum

FORMATS

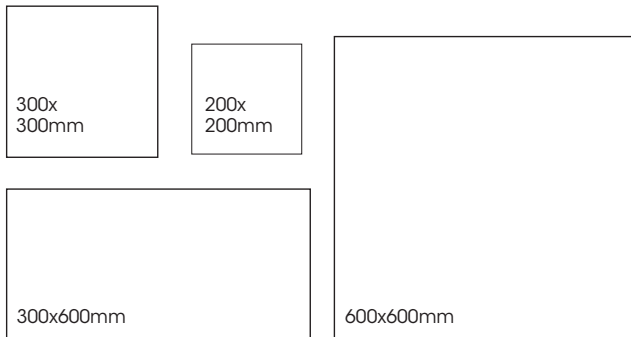

WHITE



MATT

FAWN



MATT



GRIP

Variation is an inherent property of tiles and stone. Sizes are nominal and may include a joint.

Avenue

PRODUCT SPECIFICATIONS

SIZES	FINISHES	TILE EDGE	SLIP RATING
300x300mm	MATT	RECTIFIED	P2 Pendulum
300x600mm	MATT	RECTIFIED	P2 Pendulum
600x600mm	MATT	RECTIFIED	P2 Pendulum
300x600mm	GRIP	RECTIFIED	P5 Pendulum

FORMATS

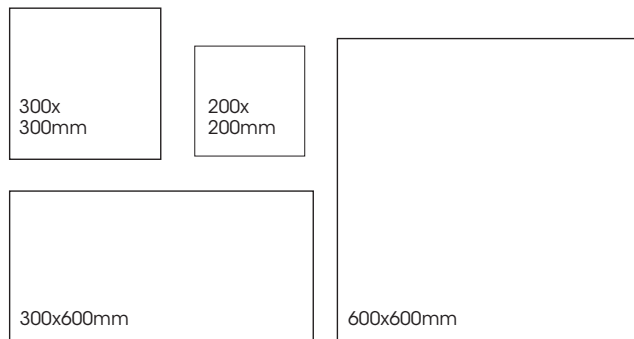

MIST



MATT



GRIP

STONE



MATT



GRIP

Variation is an inherent property of tiles and stone. Sizes are nominal and may include a joint.

Avenue



TECHNICAL DATA

technical characteristics	test method	required values	value
water absorption	iso 10545-3	$0,5\% < E \leq 3\%$	-
breaking strength (S)	iso 10545-4	$\geq 1300 \text{ N}$	pass
thermal shock resistance	iso 10545-9	no visible defects	pass
chemical resistance	iso 10545-13	Class A	pass
length and width of the average sizes	iso 10545-2	$\pm 0,5\%$	pass
thickness	iso 10545-2	$\pm 0,5\%$	pass
straightness of sides	iso 10545-2	$\pm 0,5\%$ and $\pm 1.5\text{mm}$	pass
surface quality	iso 10545-2	minimum of 95% of tiles free from visible defects	pass